

Continuous Two-Stage ABE-Fermentation using *Clostridium beijerinckii* NRRL B592 Operating with a Growth Rate in the First Stage Vessel Close to its Maximal Value

O. Mutschlechner, H. Swoboda and J.R. Gapes*

Institute of Chemical Engineering, Fuel and Environmental Technology, Vienna University of Technology, Getreidemarkt 9/159, 1060 Vienna, Austria

Abstract

A two-stage continuous cultivation experiment with *Clostridium beijerinckii* NRRL B592 is described. The experiment was designed to mimic the two phases of batch culture growth of the organism in a two-stage continuous process. Thus in the first stage turbidostat the organism was grown acidogenically as rapidly as possible, and transferred to the second stage at the 'acid break point'. The second stage was designed to mimic the solventogenesis of the batch culture when it enters late exponential/early stationary phase. The volume of the second stage vessel was calculated to provide the necessary residence time for complete sugar utilization. It was hoped that the experimental set-up chosen would show whether data obtained from batch fermentation could be transferred directly to continuous culture. The culture maintained its ability to produce acetone, 1-butanol and ethanol at a dilution rate of 0.12 h^{-1} for the first stage and $2.2 \times 10^{-2} \text{ h}^{-1}$ for the second stage and achieved an average overall solvent concentration of 15 g/l and an overall solvent productivity of 0.27 g/l/h for a period of steady-state operation of more than 1600 hours. The productivity of solventogenesis in the first stage was dependent on the value of the growth rate of the culture which was in turn determined in part by the organism employed but also by the medium composition.

Introduction

Recent interest in microbial production of acetone and butanol is based almost exclusively on investigations with strains of saccharolytic clostridia like *Clostridium acetobutylicum*, *Clostridium beijerinckii* and *Clostridium butylicum*. Strains of *Clostridium beijerinckii* are capable of producing a mixture of neutral solvents consisting either of isopropanol, 1-butanol and ethanol or of acetone, 1-butanol and ethanol by those strains lacking isopropanol dehydrogenase (Yan *et al.*, 1988). *C. beijerinckii* is able to

utilize a variety of sugars and various starch containing substrates without any additional preliminary enzymatic hydrolysis (Nimcevic *et al.*, 1998). Current developments in ABE-fermentation try to improve the economics and efficiency of the fermentation process in an attempt to challenge the petrochemical production of these solvents. One approach in this context is to access new sources of cheap substrate, for example hydrolysates of domestic waste or by-products, and waste from agriculture and food industries. The aims of the present study was firstly to provide a method for the direct transfer of data obtained from batch culture experiments with new substrates to continuous culture operation and secondly to demonstrate stable operation near the maximum growth rate of the organism.

Results

Batch Fermentation

The time course of batch fermentation (Figure 1) showed the well-known shift from acid to solvent formation that occurs towards the end of the exponential growth phase in batch cultures of solvent producing clostridia (Bahl and Gottschalk, 1988; Gapes, 1993). Shortly after the start of solventogenesis a decrease in biomass concentration can be observed, measured as a drop in the optical density and the cell concentration. This happens when the butyrate concentration reaches its maximum and the glucose utilization rate declines for a short period of time i.e. at the beginning of the acid detoxification process (Hartmanis *et al.*, 1984; Jones and Woods, 1986). After acid detoxification, the biomass concentration rises again although not as quickly as the number of cells increases. This behaviour appears to be due to a partial lysis of bacterial cells at the maximal butyrate concentration and during the detoxification period, followed by growth of much smaller clostridial cells. To obtain intact clostridial cells for continuous culture and to minimize degeneration effects the steady-state working point of the first fermentation stage was therefore established to mimic the turning-point of butyrate concentration in the acidogenic phase of the batch culture which is approximately 1.8 g/l to 2.0 g/l at the time when the rate of acid production starts to slow. This stage, indicated by the vertical grey line in Figure 1, also corresponds to a situation wherein the culture is relatively stable so that corrections can be made to counter any slight deviations of fermentation parameters without danger of inducing the acid utilization process and more complex culture behaviour.

Continuous Culture

The culture was held in steady-state for about 1600 hours to demonstrate the stability of the solvent-producing

Received October 27, 1999; revised November 20, 1999; accepted November 21, 1999. *For correspondence. Email rgapes@mail.zserv.tuwien.ac.at; Tel. +43-1-58801 15930; Fax. +43-1-58801 15999.

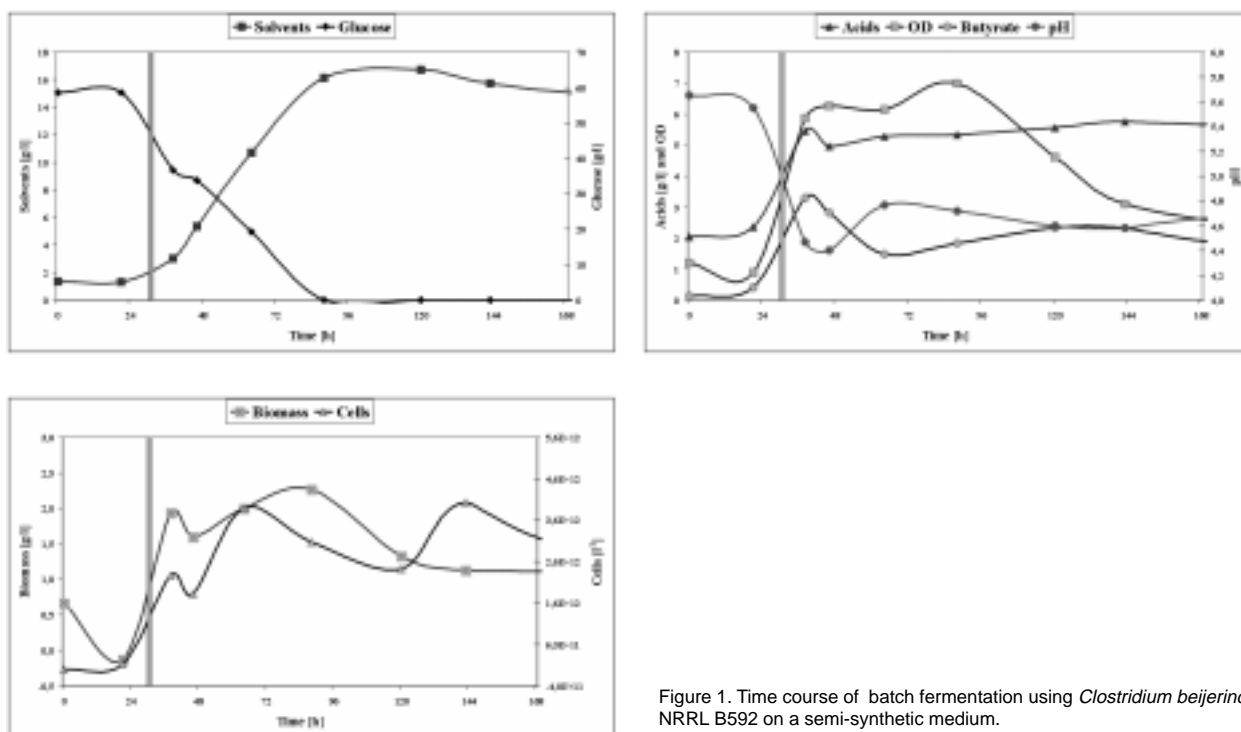

Figure 1. Time course of batch fermentation using *Clostridium beijerinckii* NRRL B592 on a semi-synthetic medium.

continuous culture. Mean values of each parameter were calculated over this steady state period and are recorded in Table 1. The curves of total solvent and glucose concentration plotted against time (Figure 2) showed periodic oscillations. Such oscillations are characteristic of continuous solvent-producing clostridial culture (Clarke

et al., 1988) and appear to be associated with high glucose concentrations in the feed (Mulchaldani and Volesky, 1994). About 15% of the glucose in the feed was assimilated in the first stage. Nearly complete sugar utilization in the second stage resulted in an average solvent concentration of 15 g/l with a peak value of 18 g/l while the solvent concentration in the first stage was generally low.

Discussion

The use of two-stage continuous solvent-producing cultures has been proposed as a method of choice for cultivation of free suspended cells (Godin and Engasser, 1989; Maddox *et al.*, 1993). However continuous cultures with immobilised biomass or biomass-retention (Maddox *et al.*, 1993; Gapes *et al.*, 1996; Nimcevic, 1996) achieve much higher solvent productivities due to the possibility of sustaining higher dilution rates. The determination of the exact biomass concentration and the distribution of the physiological state of cells, however, is very difficult in cultures operating with biomass retention, and this results in problems when scaling-up and changes of substrate are undertaken. With the experimental set-up represented in the present work, the results of batch fermentation can be transferred directly to continuous cultures with minimal effort. Scale up can also more easily be achieved.

The experiment showed only slight differences between expected values of product concentrations estimated from batch experiments and the concentrations measured in continuous culture (Table 2) whereby glucose limitation is the growth rate-limiting factor during second stage cultivation. Product inhibition is significant at a concentration of 9 g/l of 1-butanol and was countered by over-sizing the second stage. For culture medium compositions with higher glucose concentrations the use

Table 1. Fermentation Profile of *C. beijerinckii* NRRL B592 when Grown in a Two-Stage Continuous Culture on a semi-Synthetic Medium

Parameter ^a	First stage	Second stage	Overall
Temperature (°C)	34	34	
pH	4.7	5.1	
Feed rate (ml/h)	37	37	
Glucose (g/l)	50	0 ^f	1.1 ^e
Total solvents (g/l)	2.7	12 ^f	15
Acetone (g/l)	1.2	3.7 ^f	4.8
1-Butanol (g/l)	1.4	7.8 ^f	9.1
Ethanol (g/l)	0.16	0.73 ^f	0.89
A/B/E ratio ^b (%)	43:51:6	30:64:6	33:61:6
Acetic acid ^c (g/l)	5.0	-2.3 ^f	2.7
Butyric acid (g/l)	2.0	-0.39 ^f	1.6
Dilution rate (h ⁻¹)	0.12	2.2x10 ⁻²	1.8x10 ⁻²
Solvent productivity (g/l/h)	0.30	0.27	0.27
Glucose util. rate (g/l/h)	1.1	1.1	1.1
Glucose utilised (%)	16	98	98
Solvent yield ^d (g/g)	0.28	0.25	0.25

^a Average values during steady-state of fermentation.

^b Ratio of values for acetone, 1-butanol, and ethanol.

^c Acetic acid (2.0 g/l) is present in fresh medium.

^d Solvent yield was calculated from the glucose concentration (60 g/l) in the fresh medium, other carbon sources were ignored.

^e From about 600 h onwards in the second stage vessel the glucose concentration is just about 0 g/l (Figure 2). The average value of 1.1 g/l comes from taking in account the earlier peaks at the beginning of steady state.

^f Parameters were calculated as a difference between overall values and values of the first stage.

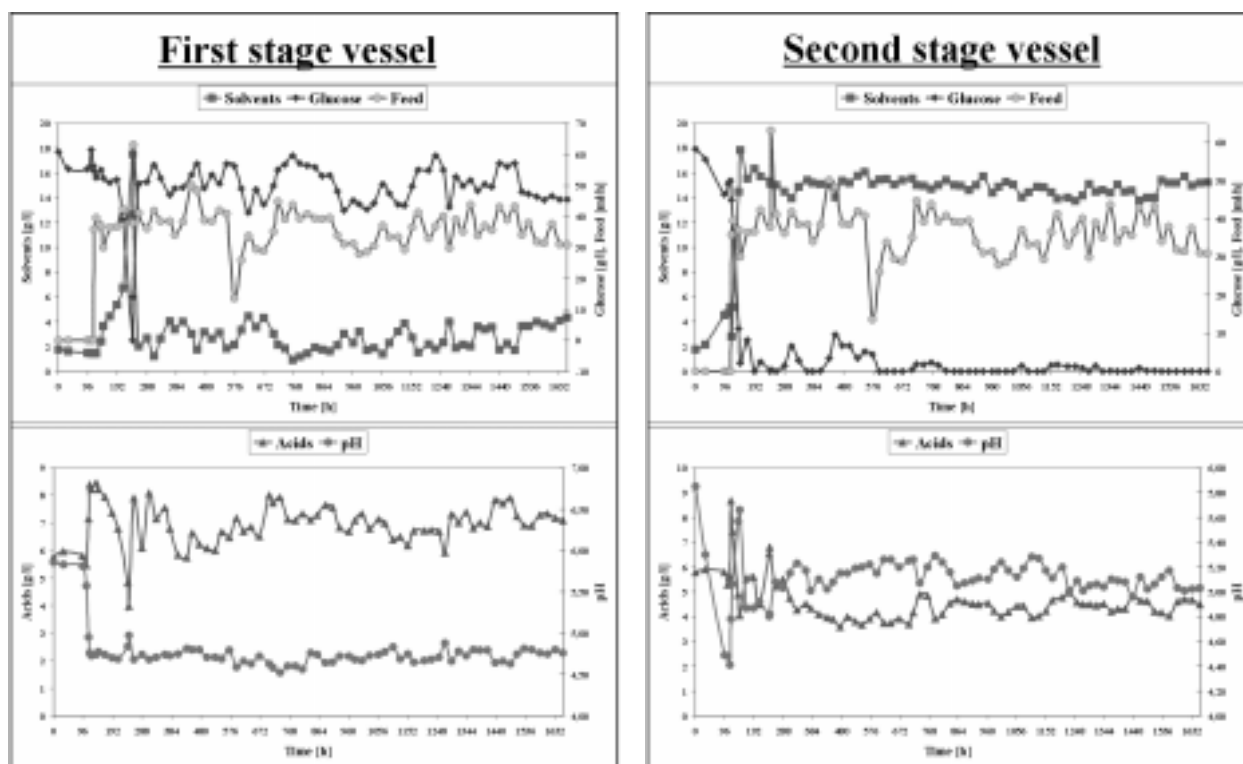

Figure 2. Time course of the two-stage continuous acetone-butanol-ethanol fermentation using *Clostridium beijerinckii* NRRL B592 on a semi-synthetic medium.

of an on-line product separation (Ennis *et al.*, 1986) such as gas stripping or membrane separation (Gapes *et al.*, 1996) enables better substrate conversion to be attained in the second stage vessel. The experimental plant was relatively stable in operation and degenerative effects like acid drift or other gradual degenerative developments were absent during the operating period. The phenomenon of degeneration is well documented (Kutzenok and Aschner, 1952; Finn and Nowrey, 1958; Gapes *et al.*, 1983; Jones and Woods, 1986; Kashket, 1995; Woolley and Norris, 1990) and will not be further discussed in this paper.

Table 2. Comparison of Average Parameters from Continuous Cultivation Experiments (measured) with Expected Parameters Estimated from Batch Fermentation Experiments

Parameter	Estimated		Measured	
	First stage	Second stage	First stage	Second stage
Glucose (g/l)	47	0	50	1.1 ^c
Acids (g/l)	4.0	5.3	7.0	4.3
Solvents (g/l)	2.2	16	2.7	15
pH	5.0	4.7	4.7	5.1
Dilution rate ^b (h ⁻¹)	0.11	2.1x10 ⁻²	0.12	2.2x10 ⁻²
Feed rate (ml/h)	35 ^a		37	

^a The 'feed rate' for batch culture was simulated by multiplying the growth rate at the 'acid break point' ($\mu=0.11\text{ h}^{-1}$) by the volume of culture medium in the first stage vessel ($V_1=325\text{ ml}$).

^b The estimated batch 'dilution rate' for the second stage vessel was calculated by dividing the estimated 'feed rate' by the volume of that stage ($V_2=1670\text{ ml}$). The estimated batch 'dilution rate' for the first stage vessel is the growth rate at the 'acid break point'.

^c see comment 'e' in Table 1.

Experimental Procedure

Organism, Culture Medium, Temperature

All experiments described in this work were performed with *Clostridium beijerinckii* NRRL B592 which is capable of producing a mixture of neutral solvents consisting of acetone, 1-butanol and ethanol. Spores were stored in sterile medium at 4°C. Cultures for batch as well as continuous fermentation were grown on a semi-synthetic medium containing 60.0 g of glucose, 5.0 g of yeast extract, 1.0 g of $\text{K}_2\text{HPO}_4 \cdot 3\text{H}_2\text{O}$, 1.0 g of KH_2PO_4 , 1.0 g of $\text{MgSO}_4 \cdot 7\text{H}_2\text{O}$, 0.5 g of $\text{FeSO}_4 \cdot 7\text{H}_2\text{O}$, 0.1 g of 4-aminobenzoic acid, 3.0 g of ammonium acetate and with distilled water to 1 litre. The fermentation temperature for both, batch and continuous operation was set to 34°C.

Analytical Methods

The determination of acids and solvents was performed by gas-chromatography with flame ionisation detection and a glass column (3.2 mm x 2.6 m) packed with a stationary phase of Chromosorb 101 at a column temperature of 170°C. Nitrogen at a flow rate of 70 ml/min was used as the carrier gas. The samples were centrifuged to separate biomass and mixed with o-phosphoric acid and 1-propanol. 1-Propanol was used as an internal standard for evaluation and the o-phosphoric acid solution had the function of an acidification agent.

The concentrations of sugars were determined by high performance liquid chromatography, using a refractive index monitor for peak detection, an Inores S259-H (250 mm x 7 mm; 9 μm) stationary phase packed with Inores cation exchange resin and a mobile phase consisting of 0.01M sulphuric acid at a flow rate of 0.45 ml/min. Separations were performed at a temperature of 70°C with glycerol as an internal standard. Calibration and analyses of solvent, acid and sugar concentrations were performed by a two-point internal standard procedure.

Optical density and the numerical concentration of cells were determined only for batch cultures due to labour intensity and their limited applicability for substrates other than synthetic media. After separation by centrifugation and washing, biomass was dried at 105°C to constant weight. Optical density was measured photometrically by determination of absorbance at a wavelength of 600nm. The number of cells per unit volume were counted microscopically at 400X magnification using a counting chamber (0.01 mm x 0.0025 mm²).

Batch Fermentation

Batch fermentations were undertaken in non-stirred reactors with a fermentation volume of 900 ml and a valve for pressure compensation. The culture medium was stripped with oxygen-free nitrogen to maintain anaerobic conditions and autoclaved at 122°C for 16 min ($V = 44$). Inoculation was with 10% (v/v) of spore suspension containing approximately 3.5×10^{12} spores of *Clostridium beijerinckii* NRRL B592 per litre. After inoculation, the fermentation medium was heat shocked for 10 min at a temperature of 80°C and cooled immediately to the appropriate incubation temperature of 34°C.

Calculation of Process Parameters for the Design of the Two-Stage Plant

To avoid wash-out of biomass from the first stage vessel the dilution rate for steady-state operation has to be set at the value of the growth rate at the desired working point and below the maximum growth rate. The average growth rate required was calculated from prior batch culture experiments. For a given set of experimental parameters (micro-organism, temperature, standardized substrate and inoculation preparation) it was found that both the growth rate and the time when the desired growth rate was achieved were dependent on medium composition alone.

$$\text{Dilution rate: } \frac{dx}{dt} = D \cdot x \Rightarrow x = x_0 \cdot e^{-Dt}$$

$$\text{Growth rate: } \frac{dx}{dt} = \mu \cdot x \Rightarrow x = x_0 \cdot e^{\mu t}$$

$$\text{Steady-state: } \frac{dx}{dt} = \mu \cdot x - D \cdot x = 0 \Rightarrow D = \mu$$

The flow rate necessary to achieve the calculated dilution rate for a first fermentation stage with given reactor volume can be calculated as follows:

$$F = D \cdot V_1 \Rightarrow F = \mu \cdot V_1 \quad (\text{assuming } D = \mu)$$

The volume of the second stage vessel was calculated to provide the necessary residence time for complete sugar utilization and to achieve maximal solvent concentration in the culture medium leaving this second stage:

$$V_2 = \Delta t \cdot F$$

In the above equations, x is the biomass in g/l at a time t in hours, x_0 is the initial biomass concentration in g/l at $t_0=0$, D is the dilution rate in h^{-1} , μ is the growth rate in h^{-1} , F is the feed rate in l/h, V_1 is the constant volume in litres of fermentation medium in the first stage, V_2 is the constant volume in litres of fermentation medium in the second stage, and Δt is the time interval in hours between the instant at which the desired value of μ is reached and that at which complete sugar utilization or maximal solvent concentration are attained in batch culture.

Calculation of Bioprocess Parameters

The overall solvent productivity in g/l/h during continuous cultivation of solvent-producing clostridia can be expressed as follows:

$$P = \frac{(C_{OUT} - C_{IN}) \cdot F}{V}$$

The substrate utilization rate in g/l/h during a continuous experiment can be expressed as follows:

$$S = \frac{(G_{IN} - G_{OUT}) \cdot F}{V}$$

The solvent yield in g/g is the ratio of the two previous expressions:

$$Y_{P/S} = \frac{P}{S}$$

The substrate (glucose) utilization in percent of initial substrate concentration can be calculated as follows:

$$U = \left(1 - \frac{G_{OUT}}{G_{IN}}\right) \cdot 100$$

In the above equations F is the flow rate in l/h, C_{IN} is the concentration of solvents in the fermentation medium entering a stage, C_{OUT} is the concentration of solvents in the outflow of the stage in g/l, G_{IN} is the concentration of substrate (glucose) in the medium entering a stage, G_{OUT} is the concentration of substrate (glucose) in the outflow of the stage in g/l, and V is the working volume.

Continuous Culture

A tower reactor made of glass, with a jacketed lower part and a volume of 450 ml was used as the first stage vessel. The second stage vessel also consisted of a tower bioreactor made of glass, with a jacketed lower part, but a total volume of 1800 ml. To ensure constant and thorough mixing the contents of each stage were re-circulated by separate peristaltic pumps at flow rates of 10 l/h for the first stage and 60 l/h for the second stage. Fresh medium was introduced into the first stage via a multi-channel peristaltic pump. The same pump was used to transport fermentation medium from the first to the second stage and from the second stage to product separation. The use of the one multi-channel peristaltic pump ensured identical flow rates of the feed and product streams for both reactors. The volume of fermentation medium in the first stage vessel was 325 ml (including 15 ml in the re-circulation loop). The second stage vessel was filled with 1670 ml of medium. The flow rates into the first and second stage vessels were kept constant. Slight deviations of volume could be corrected via a variable suction tube made of glass, on the top of both reactors. Connections between the different parts of the plant were made of silicone tubing of different diameters depending on the desired flow-rate. A heat exchanger which was heated to 70°C was inserted into the feed-line in front of the first stage, to prevent clostridial cells from migrating back through the feed-line into the containers of fresh medium. During operation, the fresh medium was stirred continuously by a magnetic stirrer and stripped with oxygen-free nitrogen. The headspaces of the first and second stage vessels were also flushed with oxygen-free nitrogen at a very low flow rate to achieve anaerobic conditions and to prevent the ingress of oxygen and bacterial contamination. Heating water was circulated through the jacketed lower part of each reactor to maintain a temperature of 34°C. The expected value of pH at steady-state was 5.0 for the first stage and 4.7 for the second stage. The dilution rate for continuous cultivation calculated from data of prior batch cultivation experiments was 0.12 h^{-1} in the first stage and $2.2 \times 10^{-2} \text{ h}^{-1}$ in the second stage i.e. the feed rate was calculated with 34.6 ml/h. The differences between these calculated values and the measured values during the continuous cultivation experiment are compared in Table 2. Fresh medium was contained in glass containers with a total volume of 15 litres, and was stripped with oxygen-free nitrogen and autoclaved at 122°C for 20 min. The feed rate was monitored by continuous measurement of the weight of fresh medium remaining. For calculation of the feed rate, the density of the medium was measured as 1.05 g/ml. An anti-foaming agent (Glanapon DG160) was added at a concentration of approximately 0.5 ml per litre of prepared medium. Continuous experiments were inoculated with batch cultures as described above in mid-exponential growth phase with high mobility and high production of fermentation gases. The ratio of batch culture medium for inoculation to the culture medium in the two stage vessels was 10% (v/v) and the medium contained approximately 1.3×10^{12} clostridial cells per litre. Subsequently the culture was operated as a batch culture until the butyrate concentration reached a range of 1.8 g/l to 2.0 g/l. At this time the multi-head feed pump was started. The elapsed time between inoculation and the start of the feed pump was 19 hours.

References

- Bahl, H., and Gottschalk, G. 1988. Microbial production of butanol/acetone. In: Biotechnology. H.J. Rehm, VCH, Weinheim. p. 1-30.
- Clarke, K.G., Hansford, G.S., and Jones, D.T. 1988. Nature and significance of oscillatory behaviour during solvent production by *Clostridium acetobutylicum* in continuous culture. Biotechnol. Bioeng. 32: 538-544.
- Ennis, B.M., Gutierrez, N.A., and Maddox, I.S. 1986. The acetone-butanol-ethanol fermentation – a current assessment. Process Biochem. 21: 131-147.
- Finn, R.K., and Nowrey, J.E., 1958. A note on the stability of clostridia when held in continuous culture. Appl. Microbiol. 7: 29-32.
- Gapes, J.R., Larsen, V.F., and Maddox I.S. 1983. A note on procedures for inoculum development for the production of solvents by a strain of *Clostridium butylicum*. J. Appl. Bacteriol. 55: 363-365.
- Gapes, J.R. 1993. The acetone-butanol-ethanol fermentation. Ph.D. thesis. Vienna University of Technology, Austria.
- Gapes, J.R., Nimcevic, D., and Friedl, A. 1996. Long-term continuous cultivation of *Clostridium beijerinckii* in a two-stage chemostat with on-line solvent removal. Appl. Env. Microbiol. 62: 3210-3219.
- Godin, C., and Engasser, J.M. 1989. Acid in the first stage is a determinant factor for the solvent production in the two-stage continuous fermentation of *Clostridium acetobutylicum*. Biotechnol. Lett. 11: 903-906.
- Hartmanis, M.G.N., Klason, T., and Gatenbeck, S. 1984. Uptake and activation of acetate and butyrate in *Clostridium acetobutylicum*. Appl. Microbiol. Biotechnol. 20: 66-71.
- Jones, D.T., and Woods, D.R. 1986. Acetone-butanol fermentation revisited. Microbiol. Rev. 50: 484-524.

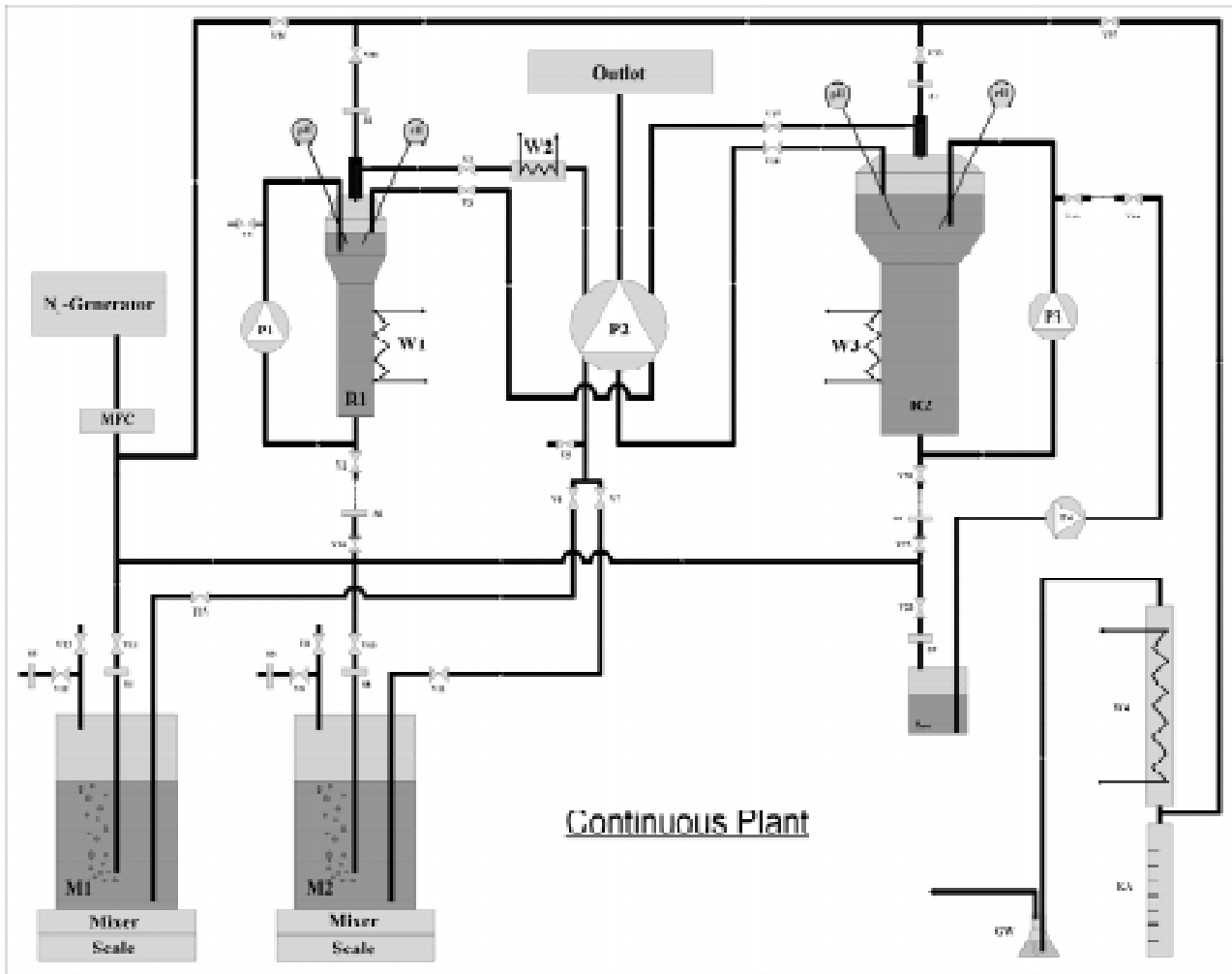

Figure 3. Experimental set-up of a two-stage continuous acetone-butanol-ethanol fermentation. The components are designated as follows: R1, first stage; R2, second stage; M1 and M2, medium containers; P1 and P3, re-circulation pumps; P2, feed pump; W1 to W4, heat exchanger; KA, condensate collecting bottle; GW, gas-wash bottle; MFC, mass flow controller; V1 to V21, valves; S1 to S5, sterile filters.

- Kashket, E.R., and Cao Z. 1995. Clostridial strain degeneration. *FEMS Microb. Reviews.* 17: 307-315.
- Kutzenok, A., and Aschner, M. 1952. Degenerative processes in a strain of *Clostridium butylicum*. *J. Bacteriol.* 64: 829-836.
- Maddox, I.S., Qureshi, N., and Gutierrez, N.A. 1993. Utilization of whey by clostridia and process technology. In: *The clostridia and biotechnology*. D.R. Woods, Butterworth-Heinemann, Boston. p. 343-369.
- Mulchaldani, A., and Volesky, B. 1994. Production of acetone-butanol-ethanol by *Clostridium acetobutylicum* using a spin filter perfusion bioreactor. *J. Biotechnol.* 34: 51-60.
- Nimcevic, D. 1996. ABE fermentation with on-line product removal. Ph.D. thesis. Vienna University of Technology, Austria.
- Nimcevic, D., Schuster, M., and Gapes, J.R. 1998. Solvent production by *Clostridium beijerinckii* NRRL B592 growing on different potato media. *Appl. Microbiol. Biotechnol.* 50: 426-428.
- Woolley, R.C., and Norris, J.G. 1990. Stability of solvent production by *Clostridium acetobutylicum* in continuous culture: strain differences. *J. Appl. Bacteriol.* 69: 718-728.
- Yan, R.T., Zhu, C.X., Golembosky, C., and Chen, J.S. 1988. Expression of solvent-forming enzymes and onset of solvent production in batch cultures of *Clostridium beijerinckii* ("*Clostridium butylicum*"). *Appl. Environ. Microbiol.* 54: 642-648.