

# Regulation of PTS Gene Expression by the Homologous Transcriptional Regulators, Mlc and NagC, in *Escherichia coli*

## (or How Two Similar Repressors Can Behave Differently)

Jacqueline Plumbridge

Institut de Biologie Physico-Chimique, (CNRS-UPR9073), 13, rue Pierre et Marie Curie, 75005 Paris, France

### Abstract

**NagC and Mlc are paralogous transcriptional repressors in *E.coli*. Unexpectedly they possess almost identical amino acid sequences in their helix-turn-helix (H-T-H), DNA binding motif and they bind to very similar consensus operator targets. Binding to each others sites can be demonstrated *in vitro* but no cross regulation can be detected *in vivo* with physiological amounts of the two proteins. Although both proteins are involved in regulating the expression of PTS genes, the characteristics of their repression and induction are very different. NagC is a dual-function, activator-repressor which co-ordinates the metabolism of the amino sugars, N-acetylglucosamine (GlcNAc) and glucosamine, by repressing the divergent *nagE-BA* operons and by activating the *glmUS* operon. Repression (and activation) by NagC requires that NagC binds simultaneously to two operators, thus forming a DNA loop. This chelation effect allows use of lower affinity sites which would not individually bind the repressor. The specific inducer for NagC is GlcNAc-6-P, the product of GlcNAc transport by the PTS and a key compound in amino sugar metabolism. Mlc represses several genes implicated in the uptake of glucose; *ptsG*, *ptsHI* and *manXYZ*, and *malT*, the activator of the *mal* regulon. Glucose behaves like the inducer but growth on glucose only produces an overall increase in expression for *ptsG* and *ptsHI*. All Mlc repressed genes are also controlled by cAMP/CAP, so that glucose affects their transcription in two opposing ways: increasing expression by acting as the inducer for Mlc but decreasing expression by lowering the cAMP/CAP concentration. The Mlc protein is not directly responsive to glucose per se but to the activity status of the PTS. Displacement of Mlc from its binding sites**

### Abbreviations

GlcNAc: N-acetylglucosamine  
 GlcN: Glucosamine  
 H-T-H: Helix-turn-helix  
 PTS: PEP dependent phosphotransferase system

\*For correspondence. Email plumbridge@ibpc.fr; Tel. 33 (0)1 58 41 51 52; Fax. 33 (0)1 58 41 50 20.

**occurs during growth on glucose and other PTS sugars and involves sequestration of the repressor to membranes by binding to dephosphorylated PtsG.**

### Introduction

Mlc and NagC are two homologous proteins (40% identical, 70% similar) of the so called ROK family (Repressors, ORFs and Kinases) (Titgemeyer *et al.*, 1994). The characterised repressors include, as well as the Mlc and NagC proteins from *Escherichia coli*, a series of repressors for xylose utilisation operons found in many Gram positive bacteria (Lokman *et al.*, 1991; Sizemore *et al.*, 1991; Gärtner *et al.*, 1992; Scheler and Hillen, 1994). Xylose is not transported by a phosphotransferase system (PTS) in either *E. coli* or the Gram positive bacteria and Mlc and NagC are the only (so far) identified repressors for PTS sugars from this family.

Since the PTS genes encode sugar uptake systems only required under specific nutrient conditions, it is obvious that their expression should be regulated. The PTS proteins form a well conserved family made up of distinct functional domains. However the regulatory mechanisms controlling their expression are very diverse. In *E. coli* expression of several PTS operons are controlled by repressors, but the repressors belong to different families of proteins. In addition to NagC and Mlc of the ROK family, there are GutR (Yamada and Saier, 1988), GatR (Nobelman and Lengeler, 1996) and AgaR (Brinkkötter *et al.*, 2000), which are members of the DeoR family. FruR, the repressor of the PTS *fru* operon (and which is also a pleiotropic regulator of glycolysis and gluconeogenesis (Saier and Ramseier, 1996)), TreR, the trehalose repressor (Horlacher and Boos, 1997) and Mall, the repressor of a PTS operon encoding an EIICB of unknown true substrate (Reidl *et al.*, 1989; Reidl and Boos, 1991), are all members of the LacI/GalR family. ChbR (ex CelD) for diacetylchitobiose, belongs to the AraC family (Parker and Hall, 1990; Keyhani and Roseman, 1997) while MtlR is a member of its own class (Figge *et al.*, 1994). Expression of the PTS *bgl* operon in *E.coli* is controlled by the transcriptional antiterminator BglG (Mahadevan and Wright, 1987; Schnetz and Rak, 1987). Similar antiterminators regulating PTS operons are frequently found in Gram positive species e.g. SacT, SacY and GlcT in *B. subtilis*. The activity of the antiterminators and also a series of transcriptional activators for PTS operons found in Gram positive species (e.g. LevR) are intricately controlled by the activity of the PTS and the availability of sugars (see Stülke *et al.*, (1998) for a review). Recent results indicate that Mlc is fulfilling a similar function in *E.coli*, that of co-ordinating the expression of the PTS with its activity.



**NagC operator sequences**

1110 9 8 7 6 5 4 3 2 1 0 1 2 3 4 5 6 7 8 9 10 11

T	T	T	A	A	T	T	T	G	C	G	A	T	A	C	G	<b>A</b>	<b>A</b>	T	T	A	A	A	<i>nagE</i>
<b>C</b>	T	T	A	T	<b>T</b>	<b>T</b>	A	T	A	T	C	A	T	T	C	<b>A</b>	<b>A</b>	A	A	A	A	<b>C</b>	<i>nagB</i>
<b>G</b>	A	T	A	T	<b>T</b>	<b>T</b>	T	A	C	C	T	T	T	C	G	<b>A</b>	<b>A</b>	A	T	T	T	<b>C</b>	<i>manX</i> distal
<b>G</b>	T	T	A	T	<b>T</b>	<b>T</b>	C	A	T	T	G	A	T	C	G	<b>A</b>	<b>A</b>	A	T	A	A	<b>G</b>	<i>glmUS</i> distal
T	C	C	A	T	<b>T</b>	<b>T</b>	C	A	C	G	A	T	G	A	A	<b>A</b>	<b>A</b>	A	A	A	T	<b>G</b>	<i>glmUS</i> proximal

**Mlc operator sequences**

1110 9 8 7 6 5 4 3 2 1 0 1 2 3 4 5 6 7 8 9 10 11

A	T	T	A	A	T	T	A	C	G	A	A	G	C	G	C	<b>A</b>	<b>A</b>	A	A	A	A	A	<i>malt</i>
T	T	A	T	T	<b>T</b>	<b>T</b>	A	G	A	T	A	G	C	G	A	<b>A</b>	<b>A</b>	A	A	A	A	T	<i>manX</i> proximal
A	T	T	A	T	<b>T</b>	<b>T</b>	C	G	G	A	G	C	G	C	G	<b>A</b>	<b>A</b>	A	T	A	T	<b>T</b>	<i>mlc</i>
T	T	A	T	T	<b>T</b>	<b>T</b>	A	C	T	C	T	G	T	G	T	<b>A</b>	<b>A</b>	T	A	A	A	T	<i>ptsG</i> p1
T	T	T	T	T	<b>T</b>	<b>T</b>	A	A	A	G	C	T	C	G	T	<b>A</b>	<b>A</b>	T	T	A	A	T	<i>ptsG</i> p2
A	T	T	A	T	<b>T</b>	<b>T</b>	T	G	A	T	G	C	G	C	G	<b>A</b>	<b>A</b>	A	T	T	A	A	<i>ptsH</i> p1

Figure 2. Alignment of native operator sites for Mlc and NagC. Sequences are aligned about the absolutely conserved TT/AA at positions -6,5/+5,6 (shown in bold with grey shading). Positions 10-7 in NagC and 11-7 in Mlc, which are either A or T are shown, by hatched shading while C or G in position 11 of NagC are shown in bold with horizontal shading.

specific base-pair recognition at this position. The crystal structures of other H-T-H proteins would suggest that it should involve an interaction in the minor groove of the DNA. At present it is not understood how the base-pair at +/-11 of the palindromic operator affects binding of NagC. NagC appears to show a stronger binding affinity for its specific sites *in vitro* than Mlc does to its sites and this can probably be ascribed to the additional binding energy due to the interaction at +/-11 (Plumbridge, 2001).

**The Targets for NagC and Mlc Regulation****1. The NagC Regulon****i. *nagE-B***

The function of NagC is to co-ordinate the utilisation of the amino sugars, N-acetylglucosamine (GlcNAc) and glucosamine (GlcN) in *E. coli*. The *nagC* gene was discovered as a member of the divergent *nagE-BACD* operons necessary for use of GlcNAc as carbon source (Plumbridge, 1989; Vogler and Lengeler, 1989; Peri *et al.*, 1990). The *nagE* gene encodes the GlcNAc specific transporter of the PTS, EIICBA<sup>Nag</sup> (Peri and Waygood, 1988; Rogers *et al.*, 1988) and *nagA* and *nagB* encode the two enzymes necessary to degrade GlcNAc-6-P (the product of the transport of GlcNAc) to fructose-6-P. The *nagA* gene encodes GlcNAc-6-P deacetylase and *nagB* codes for GlcN-6-P deaminase (White, 1968) (Figure 3). The function of *nagD* is unknown. Operators for NagC overlap the *nagE* and *nagB* promoters (the -35 and -10 consensus sequences respectively) such that the centres of the two operator sites are separated by 94 bp (Fig 4). This corresponds to 9 turns of the B-form DNA helix so

that the sites are in phase and situated on the same side of the DNA. Repression by NagC is dependent upon NagC binding simultaneously to these two operators and forming a loop of DNA. This has been demonstrated *in vitro* by the formation of hypersensitive DNaseI cleavages every 10bp in the inter-operator region and by mutagenesis *in vivo* (Plumbridge and Kolb, 1991; 1993; 1995). The role of the chelation effect afforded by DNA loop formation is to allow regulation by lower amounts of repressor and/or use of

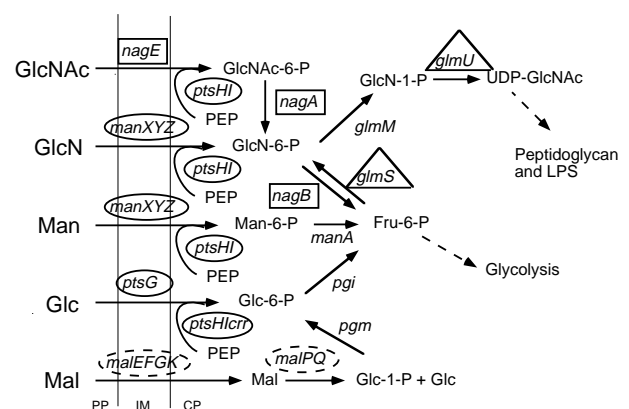

Figure 3. The Mlc and NagC regulons. Metabolism of N-acetylglucosamine (GlcNAc), glucosamine (GlcN), glucose (Glc), mannose (Man) and maltose (Mal) are shown. The genes repressed by Mlc are shown in ovals. The genes of the *mal* regulon, indicated with dotted circles, are indirectly repressed by Mlc via its effect on MalT. The *nag* genes shown in rectangles are repressed by NagC while the *glm* genes shown in triangles are activated by NagC. Cellular compartments are indicated PP, periplasm; IM, inner membrane, CP, cytoplasm.

Table 1. Regulation of *pts* operons by Mlc and NagC

	Induction							Repression	
	wt			<i>mlc</i>		<i>nagC</i>		p(Mlc)	p(NagC)
	Gly	Glc	GlcNAc	Gly	Glc	Gly	Glc	Gly/cas	Gly/cas
Fusion									
<i>nagB-E</i>	1	0.3	8	1	0.3	35	12	60	90
<i>ptsG</i>	1	7.5	7.6	18	7.6	1	7.2	>50	2
<i>ptsHI</i>	1	4	3.2	3.5	3.8	1	4.1	2.6	1
<i>manX</i>	1	0.7	1.1	3.6	0.8	1.4	0.8	>100	8

JM101 carrying the different *lacZ* fusions on single copy lambda lysogens were tested under the conditions indicated. The effect of growth on glucose (Glc) or GlcNAc, mutations in *mlc* or *nagC* and overexpression of Mlc and NagC from a plasmid are shown. Induction was measured in minimal medium with the carbon sources indicated, 0.2% Glc or GlcNAc, 0.4% glycerol (Gly). The values are the relative expression compared to that of the wild type strain in glycerol. Repression was measured in MOPS glycerol medium with 0.5% cas amino acids, 0.5 mg/ml ampicillin. The values are the relative decrease in expression compared to that in the presence of the empty vector plasmid. The *ptsHI* operon is expressed from two promoters, the Mlc regulated p0 and the effectively constitutive p1. The values given are the overall expression of the *ptsH-lacZ* fusion. The presence of p1 reduces the apparent regulatory effect of Mlc. Data are taken from (Plumbridge, 1998a; 1998b; 1999; 2001) and unpublished data.

lower affinity operators, than would be required if regulation depended upon a single site. A similar mode of *nag* operon regulation is likely in *Klebsiella pneumoniae* (Vogler and Lengeler, 1989; 1991).

#### ii. *glmUS*

NagC can also act as a transcriptional activator for the genes of the *glmUS* operon, part of the biosynthetic pathway for the formation of UDP-GlcNAc, the first dedicated component for the aminosugar components of the cell wall and outer membrane (Figure 3). In the absence of amino sugars NagC binds just upstream of one of the two *glmU* promoters, p1, and activates its expression. This binding is dependent upon an upstream "enhancer" type NagC operator (Plumbridge, 1995). Thus, as in the case of NagC repression of the *nagE-B* operons, NagC activation of *glmUS* requires co-operative binding to two in-phase operators. During growth on GlcNAc, which supplies amino sugars for cell wall components, the NagC protein is displaced from its target sites: the *glmUS*p1 promoter is inactive and the *nagE-B* promoters are derepressed. The net result of this dual activation/repression function of NagC is that during growth on carbon sources other than the amino sugars, the degradative *nag* genes are repressed and the biosynthetic *glmUS* genes are activated (Plumbridge *et al.*, 1993).

## 2. The Mlc Regulon

Mlc was identified more recently. It was isolated in several laboratories with different phenotypes although all had some association with glucose. Initially it was cloned on a multicopy plasmid for its ability to allow greater use of glucose in complex media, hence its mnemonic (making large colonies) (Hosono *et al.*, 1995). Rapid growth on glucose produces acetate via glycolysis, which leads to acidification of the medium and stops growth. The multicopy *mlc* gene prevented acetate accumulation. It was noted that the homologous *nagC* gene on a plasmid had the same effect (Hosono *et al.*, 1995). This was interpreted as indicating that Mlc was also a transcriptional regulator and that cross regulation with NagC was possible. It is now understood that excess Mlc slows down glucose uptake

so that the acetate can be dissipated before it affects the cytoplasmic pH. More recently Takeda *et al.*, (1999) made a similar observation, that multicopy Mlc or NagC prevented glucose repression of *sdhC*. In this case it is probable that the decrease in glucose transport prevented the repressing effect of glucose on *sdhC*, although the molecular mechanism was not demonstrated.

#### i. *ptsG*

Many years ago, biochemical experiments had shown that growth on glucose enhanced the levels of PtsG, the major PTS glucose transporter, EIICB<sup>Glc</sup> (Kornberg and Reeves, 1972; Saier *et al.*, 1976; Erni and Zanolari, 1986) but the control mechanism had not been further investigated. Several laboratories have now isolated mutations in *mlc* which produce increased expression of *ptsG*. Kimata *et al* (1998) isolated Tn10 insertion mutations which made *ptsG* expression constitutive and localised them to *mlc*, implying that Mlc is a repressor of *ptsG* and that the inducer was glucose. An *mlc* point mutation was found in a screen for mutants which could use ribose in the absence of the specific ribose transporter. The isolated Ribose<sup>+</sup> strains all contained two mutations, one in *mlc* leading to constitutive expression of *ptsG* and a second within the *ptsG* gene itself, changing its specificity and permitting the facilitated uptake of ribose (Oh *et al.*, 1999). In addition, Mlc mutations were found in bacterial populations which showed enhanced use of glucose in glucose-limited chemostat cultures (Manché *et al.*, 1999; Notley-McRobb and Ferenci, 1999).

The analysis of *ptsG* transcription has shown that *ptsG* is expressed from two promoters, a major gene proximal promoter, p1, and a minor upstream promoter, p2 (Figure 4). Both are subject to Mlc regulation. Mlc binds to two operator sites overlapping the -35 region of promoter p2 and the +1, -10 region of p1 (Kimata *et al.*, 1998; Plumbridge, 1998b). *ptsG* is the only identified gene controlled by Mlc which possesses two operators. The degree of induction is distinctly greater than that observed for other Mlc regulated genes, but still less than that of *nagE-B* (Table 1). As in the *nagE-B* case, co-operative binding of Mlc to the two sites could increase repression.

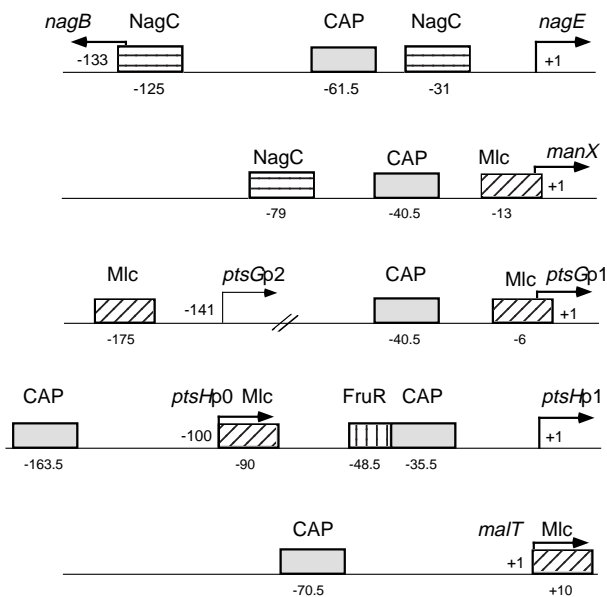

Figure 4. Organisation of NagC and Mlc binding sites in the operons that they regulate. The relative locations of the binding sites for NagC (shown by a box with horizontal lines), Mlc (hatching), FruR (verticle lines) and CAP sites (shaded) in the regulatory regions of the different operons are indicated. Promoters are shown by bent arrows. Sequences are numbered from the transcription start site (+1) of the genes given on the right of the figure. The locations of the centres of symmetry of each operator are given under each box.

DNA fragments carrying the individual *ptsG* operators have lower affinity for Mlc than the fragment with both sites which is very suggestive of co-operative binding. The distance between the centres of the two operator sites (169 bp) is much greater than in the case of *nagE-B* (94 bp). No hypersensitive DNaseI cleavage sites, which are characteristic of DNA loop formation, were detected. However the greater flexibility produced by the longer interoperator distance probably precludes their formation.

#### ii. *ptsHI*

De Reuse and Danchin (1991) had previously noted that the *ptsHI* genes, encoding the common central components of the PTS, HPr and Enzyme I, were induced by growth on glucose. The third gene of the operon *crr*, encoding EIIA<sup>Glc</sup> was not induced but the majority of its expression is due to its own promoters internal to *ptsI*. Two promoters were mapped upstream of *ptsH* but only p0, the upstream promoter, was subject to glucose induction (De Reuse *et al.*, 1992; Fox *et al.*, 1992). Knowledge that relief of Mlc repression was responsible for the glucose induction of *ptsG* prompted several laboratories to test and demonstrate that Mlc also intervened in the glucose induction of the *ptsHp0* promoter. Mlc binds to a site overlapping the p0 transcriptional start site (Figure 4) (Kim *et al.*, 1999; Plumbridge, 1999; Tanaka *et al.*, 1999). Previously a binding site for the FruR (Cra) regulator had been located in the *ptsHI* regulatory region upstream of p1 (Ramseier *et al.*, 1993). Although FruR (Cra) affects many genes involved in glycolysis or gluconeogenesis (Saier and Ramseier, 1996), it was shown to only affect the expression of *ptsHp1* expression and not to be responsible for the glucose induction of *ptsHp0* (Ryu *et al.*, 1995).

#### iii. *manXYZ*

Glucose is not only transported by its specific PTS transporter, PtsG, but also by the so called Mannose PTS, EIIABCD<sup>Man</sup>, encoded by the *manXYZ* operon (Curtis and Epstein, 1975; Kornberg and Jones-Mortimer, 1975). This rather generic transporter is also capable of taking up GlcN and GlcNAc. In fact, under normal conditions, it is the only transporter for GlcN. Previously Vogler and Lengeler (1989) had noted that overproduced NagC inhibited the uptake of mannose, implying that *manXYZ* could be part of the NagC regulon. Indeed DNaseI footprinting demonstrated two binding sites for NagC in the *manX* promoter region, of which the downstream one overlapped the -10 and +1 of the *manXYZ* promoter (Figure 4) (Plumbridge and Kolb, 1991). However little regulation by NagC was detected *in vivo*, while an *mlc* mutation was found to produce a three fold derepression of *manXYZ* expression (Table 1) (Plumbridge, 1998a). Although there is some logic in including *manXYZ* in the NagC regulon, because it is the only transporter for GlcN, clearly *ManXYZ* is more strongly subject to Mlc regulation than NagC. The difference in efficiency of regulation by NagC and Mlc on *manXYZ* expression can be understood when one considers the location and affinity of the two operators for Mlc and NagC. The promoter distal site (centred at -79) has a higher affinity for NagC while the promoter proximal site (centred at -13) has a higher affinity for Mlc (Plumbridge, 1998a). Binding of NagC at -79 would not be expected to inhibit transcriptional initiation by RNA polymerase. On the other hand binding of Mlc over the -10 sequence should interfere with RNA polymerase binding. Overexpression of NagC from a multicopy plasmid allows NagC to bind to the promoter proximal site and hence repress *manXYZ* expression. It is probable that the *mlc* gene is coincident with the previously described *dgsA* locus affecting 2-deoxyglucose sensitivity and *manXYZ* expression (Roehl and Vinopal, 1980; Plumbridge, 1998a).

#### iv. *malt*

Independently Decker *et al* (1998) had isolated Tn10*kan* mutations in *mlc* which increased the expression of genes of the *mal* regulon. Further investigation showed that this activation of *mal* gene expression was due to increased amounts of MalT, the transcriptional activator of the *mal* regulon. Mlc was shown to repress the transcription of *malt* so that an *mlc* mutation produced a 3-4 fold increase in MalT levels and indirectly in the genes of the *mal* regulon. Maltose is not a PTS sugar but it was noted that maltose degradation produces intracellular Glc and Glc-1-P, thus providing another connection with glucose metabolism.

#### Role of cAMP/CAP in Mlc and NagC Regulation

There was an apparent paradox in the observation that *ptsHp0* is regulated by cAMP/CAP but that it is also induced by glucose (De Reuse *et al.*, 1992; Ryu and Garges, 1994). Growth on glucose reduces the concentration of cAMP and generally limits expression from CAP activated genes (reviewed in Saier *et al.*, 1996). Both *ptsH* and *ptsG* are induced by growth on glucose but expression of *manX* and *malt* is decreased (Table 1 and Decker *et al.*, 1998). Expression of all four operons is under control of cAMP/

CAP. Indeed it was shown that, in a strain depleted for cAMP or CAP, no *ptsHp0* nor *ptsGp1* transcripts were detected (Kimata *et al.*, 1998; Plumbridge, 1998b; 1999; Tanaka *et al.*, 1999), so that even utilisation of glucose, the preferred carbon source, requires some level of cAMP/CAP. All Mlc controlled promoters (except the minor *ptsGp2*) are absolutely dependent upon cAMP/CAP but the levels of cAMP/CAP that they require for efficient transcription are different: *ptsG* and *ptsHp0* are activated with the lower levels of cAMP/CAP present in glucose grown cells while *manX*, *malT* require higher amounts. The expression of *ptsH* is the same in wild-type strains growing on glucose or in a *mlc* strain growing on glycerol implying that the cAMP/CAP concentration present during growth on glucose is sufficient for full activation. In the absence of Mlc repression, the *ptsGp1* promoter can synthesise higher levels of mRNA in low catabolite repression media like glycerol than in glucose. The expression of *ptsG* is induced 7-8 fold by growth on glucose but it is two fold higher in an *mlc* strain growing on glycerol. On the other hand the *malT* and *manX* promoters require higher concentrations of cAMP/CAP to be activated so that even in an *mlc* strain their expression is lower in glucose than glycerol. It is significant that, for all four genes, the level of expression in glucose is identical in *mlc*<sup>+</sup> and *mlc* strains. This means that it is the level of cAMP/CAP which determines the final expression level. The ability of glucose to displace Mlc from its operators is not the limiting factor, rather it is the effect of glucose on the level of cAMP/CAP. Conventional wisdom says that if *ptsHp0* requires the lowest amount of cAMP/CAP for full activity then it should have the best CAP site. However *in vitro* binding experiments showed that the *ptsHp0* CAP site was rather weak (De Reuse *et al.*, 1992; Ryu and Garges, 1994): this is another paradox which needs to be resolved.

Expression of the *nag* genes, like most catabolic operons, is also dependent upon cAMP/CAP. The relatively low level of induction of *nagE* expression by growth on N-acetylglucosamine is due predominately to the catabolic repression effect exerted by GlcNAc (Dobrogosz, 1968). In addition growth on GlcNAc probably leads to incomplete displacement of NagC from its target sites. As for Mlc controlled genes, *nagE* expression is essentially eliminated by a *cya* or *crp* mutation. On the otherhand *nagB* expression is only reduced about three fold by a *crp* mutation (Plumbridge and Kolb, 1993; 1998). Moreover this low activation appears to be primarily due to a structural effect of CAP on the topology of the DNA. When CAP binds to DNA it bends the DNA which can enhance RNA polymerase binding, even in the absence of direct contacts between activation regions on CAP and one or other subunit of the polymerase. Binding of CAP and NagC to the *nagE-B* intergenic region is co-operative and, although direct proof is lacking *in vivo*, it is likely that CAP is present as a structurally stabilising influence in the repression loop (Plumbridge and Kolb, 1998). In this sense cAMP/CAP is playing a similar role to its function as co-repressor in repression of CytR controlled genes (reviewed in Valentin-Hansen *et al.*, (1996)) or to HU in helping GalR to form a DNA loop for repression of *galETK* (Aki *et al.*, 1996; Aki and Adhya, 1997). However unlike in these two cases, where the accessory protein is essential for repression,

cAMP/CAP is not necessary for *nagE-B* repression. We can hypothesise that the presence of the activator, cAMP/CAP, in the repressed complex allows rapid induction of *nag* genes when GlcNAc is sensed in the environment. In contrast to NagC, there is no evidence for co-operative binding between Mlc and cAMP/CAP.

### Induction of Genes Controlled by NagC and Mlc

The standard dogma is that induction of prokaryotic regulators is due to the binding of a small signalling molecule to the regulatory protein, either activator or repressor. Binding of the inducer produces an allosteric change in the protein which prevents its inhibitory action or permits its activator function. The inducing molecule is generally related to the metabolism of the gene products whose synthesis is controlled: e.g. allolactose for the *lac* operon and maltotriose for the *mal* regulon. In this respect NagC appears to be a classical prokaryotic regulator. Both genetic and biochemical evidence support the identification of GlcNAc-6-P as the inducer for NagC (Plumbridge, 1991). GlcNAc-6-P is the product of the transport of GlcNAc by the PTS and it is the key compound in the regulation of amino sugar metabolism in *E. coli*, both at the level of enzyme synthesis and of enzyme activity. Intracellular GlcNAc-6-P is the signal which shifts the bacteria from activation of the biosynthetic *glmUS* operon and repression of the degradative *nagE-BA* genes to a reduction in *glmUS* synthesis and induction of *nagE-BA* expression. In addition, GlcNAc-6-P exerts its effect on amino sugar metabolism at a second level, since it is the allosteric activator of the second enzyme of the degradative pathway, GlcN-6-P deaminase encoded by *nagB* (Calcagno *et al.*, 1984).

Early on it was realised that the Mlc repressor controlled operons associated with the utilisation of glucose as a carbon source. However there was no obvious candidate derivative of glucose which could act as a specific ligand for Mlc. The product of glucose transport by the PTS, Glc-6-P, is the same as that produced by the uptake of Glc-6-P by the *uhp* system. Whereas growth on glucose leads to induction of *ptsG* and *ptsH* expression, growth on Glc-6-P does not. On the other hand it was observed that the non-metabolisable glucose analog,  $\alpha$ -methylglucoside, which is transported by the PTS, produced induction of *ptsG* and *ptsH* (Plumbridge, 1999). These observations lead to the idea that it was the activity of the PTS that was being monitored by Mlc rather than the metabolism of glucose *per se*. This idea was reinforced by the observation that growth on other PTS sugars, and not just glucose, lead to induction of *ptsG* and *ptsH*. The level of induction was variable; "good" PTS sugars like N-acetylglucosamine or mannitol could produce induction comparable to glucose (Table 1) but induction was lower for fructose or mannose. The PTS proteins, which form a cascade to pass a phosphate from PEP via Enzyme I and HPr to the sugar specific Enzyme IIs and hence to the sugar, are considered to be predominately dephosphorylated during growth on a PTS sugar. Although growth on a given sugar specifically dephosphorylates the IIB and IIA proteins for that sugar, there is some equilibration of the phosphates and cross dephosphorylation occurs from other IIB and IIA domains (e.g. see Vogler *et al.*, (1988)). In addition it was observed

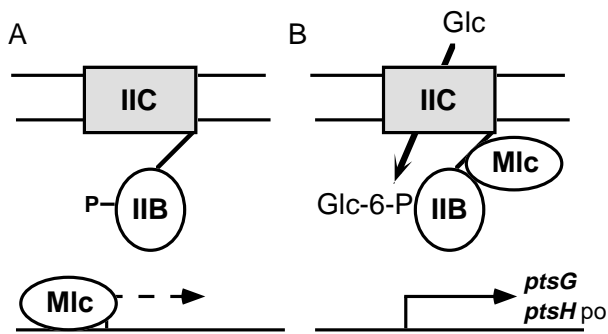

Figure 5. Model for PtsG regulation of Mlc induction. PtsG (EIICB<sup>Glc</sup>) is shown as a membrane anchored IIC domain and a soluble IIB domain joined by a linker. A) In the absence of glucose, PtsG is predominately phosphorylated and Mlc is bound to its operators. B) During growth on glucose, IIB<sup>Glc</sup> becomes dephosphorylated, Mlc binds to PtsG containing membranes and Mlc controlled genes are derepressed.

that mutations which interrupt the phosphate transfer from PEP to EIICB<sup>Glc</sup> (*ptsHIcrr*) also provoked derepression of Mlc controlled genes (De Reuse and Danchin, 1991; Plumbridge, 1999; Tanaka *et al.*, 2000; Zeppenfeld *et al.*, 2000). Moreover EIICB<sup>Glc</sup>, encoded by *ptsG*, seemed to be a key intermediate since strains lacking *ptsG* were noninducible. Together these results converged on the idea that dephosphorylated PtsG is necessary for Mlc induction and lead to a novel model for Mlc regulation. Induction was proposed to involve the sequestration of Mlc to dephosphorylated PtsG in the membrane (Figure 5). Biochemical evidence showing a physical association of Mlc to membranes containing PtsG has recently been published (Lee *et al.*, 2000; Tanaka *et al.*, 2000). The membrane association of PtsG was shown to be modulated by the transport of glucose or phosphorylation by the PTS system, showing it had the characteristics predicted by the model. Since growth on glucose leads to higher levels of PtsG in the membrane, this should increase sequestration of Mlc and increase induction i.e. a positive feed-back loop mechanism (Tanaka *et al.*, 2000). The involvement of cAMP/CAP in controlling *ptsG* expression should prevent this system exploding.

PtsG protein consists of two PTS domains; the integral membrane IIC domain and the soluble IIB domain which carries the Cys421 phosphorylation site. Membrane association seems to be the important criteria for regulation of Mlc because the soluble IIB domain was not active in regulation. On the other hand PtsG variants with large deletions within the IIC domain, but which were still bound to membranes, were also capable of binding Mlc and allowing induction of Mlc regulated genes (Lee *et al.*, 2000). At the moment we do not know whether the membrane association is sufficient to physically separate the repressor Mlc protein from DNA or whether some conformational change (i.e. an allosteric effect) occurs in Mlc when it interacts with PtsG or possibly some other membrane component. A series of mutations in *ptsG* have recently been characterised which change both the sugar transport specificity of PtsG and affect its regulation by Mlc (Notley-McRobb and Ferenci, 2000; Plumbridge, 2000; Zeppenfeld *et al.*, 2000). The existence of such mutations confirms

the regulatory link between PtsG and Mlc but as the mutations are predominately located in the membrane spanning IIC domain it is less obvious how they alter Mlc regulation, which requires the IIB domain. They must affect the conformational coupling between the two domains.

Although the primary regulatory mode of Mlc when it inhibits use of glucose, must be its effect on *ptsG* transcription, recent experiments have shown that Mlc binding to PtsG can also inhibit its enzymatic functions. Both phosphorylation of  $\alpha$ -methylglucoside by PtsG and phosphorylation of PtsG by EIIA<sup>Glc</sup> were reduced in the presence of Mlc *in vitro* (Lee *et al.*, 2000). These experiments were carried out with excess Mlc and it is not yet known whether this inhibition has any physiological significance. The intracellular concentration of Mlc has not been reported but normally, regulatory proteins like Mlc, are expected to be present in much lower amounts than PtsG which is a major sugar transporter. The very efficient repression of glucose utilisation by overproduced Mlc (as originally observed by Hosono *et al.* (1995)) could perhaps be explained by this physical inhibition. Excess Mlc represses PtsG expression and the lower amounts of PtsG which are synthesised and integrated into the membrane are subsequently inactivated by binding Mlc.

NagC and Mlc are homologous throughout their lengths and not just in the functionally conserved DNA binding N-terminal region (Figure 1). The conservation in their DNA binding domains is reflected in their binding to similar operator sequences. The C-terminal three quarters of the proteins are presumably responsible for the effector binding and multimerisation functions of the protein which should modulate their DNA binding capacities. However the signals responsible for provoking the displacement of Mlc and NagC from their DNA targets, seem to have considerably evolved. It should be recalled that other members of the ROK family are expected to bind sugars and/or sugar phosphates. Sugars and sugar phosphates are the substrates and products of the enzymatic reaction of the glucose/fructose kinases. The inducer for NagC is the phosphorylated form of GlcNAc, while for the XylR repressors it is free xylose (Gärtner *et al.*, 1992). Interestingly Glc-6-P has been shown to have an antagonistic role to xylose in regulating XylR (Dahl *et al.*, 1995). Although the current model for Mlc induction requires PtsG to displace Mlc from its binding sites, it is not excluded that a sugar or sugar-phosphate is also necessary for this interaction.

### Is There Cross Talk Between the Mlc and NagC Regulons?

The Mlc and NagC proteins bind specifically to each others sites *in vitro* as shown by DNaseI footprinting. The only exception so far is that no binding of NagC to the *malT* operator was detected (Decker *et al.*, 1998). Although they can bind to each others sites *in vitro*, no cross regulation by physiological levels of Mlc or NagC is detected *in vivo*. This means that *mlc* mutations do not affect expression of the *nagE-B* operons and *nagC* mutations do not affect Mlc controlled genes (Table 1). The *manXYZ* operon with both NagC and Mlc sites shows very weak induction by *nagC*. On the otherhand excess of either protein, supplied by

multicopy plasmids, produces repression (Table 1).

As described above, the major difference between Mlc and NagC binding sites is the presence of a C or G at positions +/-11 of the operator in NagC sites. Rather surprisingly the *nagE* operator has AT at these positions and thus appeared to have the characteristics of an Mlc site (Figure 2). No regulation of the wild-type *nagB-E* operons by *mlc* was detected *in vivo* but this could be because Mlc binding was prevented by preferential occupation by NagC. NagC binding to the wild-type *nagE* operator is dependent upon DNA loop formation driven by the higher affinity *nagB* operator. Even in the absence of NagC regulation (either in a *nagC* strain or using a *nagE-lacZ* fusion which is no longer capable of forming a DNA loop), no or very little regulation by the chromosomally encoded copy of *mlc* was observed. However excess Mlc from a multicopy plasmid did strongly repress *nagE* and was in fact much better than NagC in this case (Plumbridge, 2001). Exchanging the A/T at positions +/-11 for C/G produced a very high affinity NagC operator which was bound by NagC even in the absence of the second *nagB* operator (Plumbridge and Kolb, 1995).

Thus the intracellular concentrations of NagC and Mlc and the inherent binding affinities of the native Mlc and NagC sites are well balanced so that no cross regulation occurs. NagC, with an intrinsically higher affinity for its specific sites, appears to use lower affinity sites together with DNA loop formation to produce a greater range of repression and derepression. On the other hand Mlc mediates lower magnitude changes, only 3-4 fold. The increase with *ptsG* is greater, up to 18 fold and this could be due to co-operative binding of Mlc to the two operators upstream of *ptsG*. The fact that induction by *mlc* is relatively weak but that repression by excess Mlc is very strong (>100 fold) implies that Mlc operators are only weakly occupied during normal conditions. This could be because either Mlc concentrations are low or the affinity of the natural binding sites is low. A further interesting question is what are the relative levels of Mlc and PtsG in the cell.

The observation that growth on other PTS sugars, in addition to glucose, also induces Mlc controlled genes, means that a second type of cross regulation is also possible, and does occur. Thus growth on GlcNAc induces not only the expression of genes specific for its own transport and metabolism but also those of the Mlc regulon. Of these, Enzyme I and HPr encoded by *ptsHI* genes, are indeed necessary for growth on GlcNAc but PtsG is not. GlcNAc produces appreciable catabolite repression (Dobrogosz, 1968) and so unnecessary induction of *malT* and *manXYZ* is avoided in the same way as it is during growth on glucose, by limiting the supply of cAMP/CAP.

It must be admitted that for standard laboratory cultures, growing rapidly with excess nutrients, it is difficult to envisage conditions where Mlc regulation of *manXYZ* or *malT* could have a useful or discernable effect. However conditions in natural habitats are very different; the concentrations of carbon sources in the environment are much lower and the bacteria are likely to be presented with a mixture of several components. Slow growth on low concentrations of glucose actually leads to an increase in the cAMP concentration (Notley-McRobb *et al.*, 1997) so that simultaneous use of glucose and other carbon sources

is possible and can be observed in this situation (reviewed in Kvaraova-Kovar and Egli, (1998); Ferenci, (1999)). Thus it would be advantageous for a bacteria growing on low amounts of glucose (or GlcNAc) to be able to increase the levels of the enzymes necessary for use of mannose and maltose. This scenario, simultaneous induction of Mlc controlled genes during slow growth on glucose, needs to be experimentally verified in chemostat cultures, the nearest laboratory equivalent to natural environments.

### Concluding Remarks

The comparison of Mlc and NagC has shown two major differences in their activities. Firstly the specificity of their binding sites. The quasi-identity of their H-T-H motifs and operator sequences implies that the primary sources of protein-DNA interaction are the same. This needs, of course, to be confirmed by crystallography. However discrimination between NagC and Mlc sites does occur and appears to involve the bases located at +/-11 of the operator palindrome i.e. at sites separated by two turns of the DNA helix. This unprecedented situation is based on the observation that C/G at this position enhances NagC binding. However it should be admitted that a C or a G at these positions does not eliminate Mlc binding, implying that other criteria are important in determining Mlc and NagC binding affinity (Plumbridge, 2001). Secondly their mode of induction by growth on sugars is very different. Induction of Mlc controlled genes involves a spatial relocation of Mlc to the cytoplasmic membrane. One other example of sequestration of a regulatory protein to the membrane has been described previously. The bifunctional PutA protein in *Salmonella typhimurium* has an enzymatic activity, degrading proline to glutamate, when inserted in the membrane which prevents it binding to DNA (Ostrovsky de Spicer and Maloy, 1993; Muro-Pastor *et al.*, 1997). Another example where a membrane associated protein antagonises the activity of a transcriptional regulator, concerns the MalK subunit of the maltose transporter and MalT (Panagiotidis *et al.*, 1998). It will be interesting to see if this could be a common mechanism of coupling uptake of nutrients across the membrane with their subsequent catabolism.

The original description and sequence of the *mlc* gene did not allow any certain identification of its function. The authors isolated it because on a plasmid it enhanced use of glucose on complex media containing glucose and so produced larger colonies, thus they called it Mlc for making large colonies. Previously Roehl and Vinopal (1980) had isolated mutations in a gene controlling *manXYZ* expression. The mannose PTS is the major uptake system for 2-deoxyglucose and because their mutation made the cells sensitive to 2-deoxyglucose they called the mutation *dgsA*, for 2-deoxyglucose sensitivity. Subsequent analysis showed that this mutation is probably allelic with *mlc* (Plumbridge, 1998a). Although the 2-deoxyglucose sensitivity is probably the simplest phenotype associated with the *mlc* gene, regulation of *manXYZ* seems only part of Mlc's functions. However esoteric and inhabitual Mlc is, as a name for a gene locus in prokaryotes, *dgsA* does not seem to be much more pertinent. One can make a case to rename the gene to reflect its function as a regulator of the

PTS, (e.g. *ptsR*) or of glucose utilisation (e.g. *glcR*) depending upon what you consider to be its major function. However multiple renaming of genes can cause confusion, especially for people not intimately involved with the subject. Thus I propose that we retain the name Mlc, which has been used by the majority of the laboratories working on this subject. Perhaps we can consider it as the mnemonic for membrane linked control. After all an unusual name is maybe opportune for the first member of an unusual class of prokaryotic regulators.

#### Acknowledgements

I am pleased to acknowledge many useful discussions with Annie Kolb and Winfried Boos. I thank Claude Portier for comments on the manuscript.

#### References

- Aki, T., and Adhya, S. 1997. Repressor induced site specific binding of HU for transcriptional regulation. *EMBO J.* 16: 3666-3674.
- Aki, T., Choy, H.E., and Adhya, S. 1996. Histone-like protein HU as a specific transcriptional regulator: cofactor role in repression of *gal* transcription by Gal repressor. *Genes to Cells* 1: 179-188.
- Angell, S., Lewis, C.G., Buttner, M., and Bibb, M.J. 1994. Glucose repression in *Streptomyces coelicolor* A3(2): a likely regulatory role for glucose kinase. *Mol. Gen. Genet.* 244: 135-143.
- Angell, S., Schwarz, E., and Bibb, M.J. 1992. The glucose kinase gene of *Streptomyces coelicolor* A3(2): its nucleotide sequence, transcriptional analysis and role in glucose repression. *Mol. Microbiol.* 6: 2833-2844.
- Brinkkötter, A., Klöss, H., Alpert, C.-A., and Lengeler, J.W. 2000. Pathways for the utilization of N-acetyl-galactosamine and galactosamine in *Escherichia coli*. *Mol. Microbiol.* 37: 125-135.
- Busby, S., and Ebright, R. 1999. Transcription activation by catabolite activator protein (CAP). *J. Mol. Biol.* 293: 199-213.
- Calcagno, M., Campos, P.J., Mulliert, G., and Suastegui, J. 1984. Purification, molecular and kinetic properties of glucosamine-6-phosphate isomerase (deaminase) from *E.coli*. *Biochem. Biophys. Acta* 787: 165-173.
- Curtis, S.J., and Epstein, W. 1975. Phosphorylation of D-glucose in *Escherichia coli* mutants defective in glucosephosphotransferase, mannosephosphotransferase and glucokinase. *J. Bacteriol.* 122: 1189-1199.
- Dahl, M.K., Schmiedel, D., and Hillen, W. 1995. Glucose and Glucose-6-phosphate interaction with Xyl repressor proteins from *Bacillus* spp. may contribute to regulation of xylose utilization. *J. Bacteriol.* 177: 5467-5472.
- De Reuse, H., and Danchin, A. 1991. Positive regulation of the *pts* operon of *Escherichia coli*: Genetic evidence for a signal transduction mechanism. *J. Bacteriol.* 173: 727-733.
- De Reuse, H., Kolb, A., and Danchin, A. 1992. Positive regulation of the expression of the *Escherichia coli pts* operon. Identification of the regulatory regions. *J. Mol. Biol.* 226: 623-635.
- Decker, K., Plumbridge, J., and Boos, W. 1998. Negative transcriptional regulation of a positive regulator: the expression of *malT*, encoding the transcriptional activator of the maltose regulon of *Escherichia coli*, is negatively controlled by Mlc. *Mol. Microbiol.* 27: 381-390.
- Dobrogosz, W.J. 1968. Effect of amino sugars on catabolite repression in *Escherichia coli*. *J. Bacteriol.* 95: 578-584.
- Erni, B., and Zanolari, B. 1986. Glucose-permease of the bacterial phosphotransferase system. Gene cloning, overproduction and amino acid sequence of Enzyme II<sup>Glc</sup>. *J. Biol. Chem.* 261: 16396-16403.
- Ferenci, T. 1999. Regulation by nutrient limitation. *Curr. Opin. Microbiol.* 2: 208-213.
- Figge, R.M., Ramseier, T.M., and Saier, M.H. 1994. The mannitol repressor (MtlR) of *Escherichia coli*. *J. Bacteriol.* 176: 840-847.
- Fox, D.K., Presper, K.A., Adhya, S., Roseman, S., and Garges, S. 1992. Evidence for two promoters upstream of the *pts* operon: regulation by the cAMP receptor protein regulatory protein. *Proc. Natl. Acad. Sci. USA* 89: 7056-59.
- Gärtner, D., Degenkolb, J., Ripperger, J.A.E., Allmansberger, R., and Hillen, W. 1992. Regulation of the *Bacillus subtilis* W23 xylose utilization operon: interaction of the Xyl repressor with the *xyl* operator and the inducer xylose. *Mol. Gen. Genet.* 232: 415-422.
- Geanacopoulos, M., and Adhya, S. 1997. Functional characterisation of roles of GalR and GalS as regulators of the *gal* regulon. *J. Bacteriol.* 179: 228-234.
- Gunasekera, A., Ebright, Y.W., and Ebright, R.H. 1992. DNA sequence determinants for binding of the *Escherichia coli* catabolite gene activator protein. *J. Biol. Chem.* 267: 14713-14720.
- Horlacher, R. and Boos, W. 1997. Characterization of TreR, the major regulator of the *Escherichia coli* trehalose system. *J. Biol. Chem.* 272: 13026-13032.
- Hosono, K., Kakuda, H., and Ichihara, S. 1995. Decreasing accumulation of acetate in rich medium by *Escherichia coli* on introduction of genes on a multicopy plasmid. *Biosci. Biotech. Biochem.* 59: 256-261.
- Keyhani, N.O., and Roseman, S. 1997. Wild-type *Escherichia coli* grows on the chitin disaccharide, N,N'-diacetylchitobiose, by expressing the *cel* operon. *Proc. Natl. Acad. Sci. USA* 94: 14367-14371.
- Kim, S.-Y., Nam, T.-W., Shin, D., Koo, B.-M., Seok, Y.-J., and Ryu, S. 1999. Purification of Mlc and analysis of its effects on the *pts* expression in *Escherichia coli*. *J. Biol. Chem.* 274: 25398-25402.
- Kimata, K., Inada, T., Tagami, H., and Aiba, H. 1998. A global repressor (Mlc) is involved in glucose induction of the *ptsG* gene encoding major glucose transporter in *Escherichia coli*. *Mol. Microbiol.* 29: 1509-1519.
- Kornberg, H., and Jones-Mortimer, M.C. 1975. *PtsX*: A gene involved in the uptake of glucose and fructose by *Escherichia coli*. *FEBS Lett.* 51: 1-4.
- Kornberg, H.L., and Reeves, R.E. 1972. Inducible phosphoenolpyruvate-dependent hexose phosphotransferase activities in *Escherichia coli*. *Biochem. J.* 128: 1339-1344.
- Kvaraova-Kovar, K., and Egli, T. 1998. Growth Kinetics of suspended microbial cells: From single-substrate-controlled growth to mixed substrate kinetics. *Microbiol. Mol. Biol. Rev.* 62: 646-666.
- Lee, S.-J., Boos, W., Bouché, J.-P., and Plumbridge, J. 2000. Signal transduction between a membrane bound transporter PtsG, and a soluble transcription factor, Mlc, of *Escherichia coli*. *EMBO J.* 19: 5353-5361.
- Lehming, N., Sartorius, J., Kisters-Woike, B., von Wilken-Bergman, B., and Müller-Hill, B. 1991. Rules for protein DNA recognition for a family of helix-turn-helix proteins. *Nucleic Acids and Molecular Biology* 5: 114-125.
- Lewis, M., Chang, G., Horton, N.C., Kercher, M.A., Pace, H.C., Schumacher, M.A., Brennan, R.G., and Lu, P. 1996. Crystal structure of the lactose operon repressor and its complexes with DNA and inducers. *Science* 271: 1247-1254.
- Lokman, C., van Santen, P., Verdoes, J.C., Krüse, J., Leer, R.J., Posno, M., and Pouwels, P.H. 1991. Organisation and characterisation of the three genes involved in D-xylose catabolism in *Lactobacillus pentosus*. *Mol. Gen. Genet.* 230: 161-169.
- Mahadevan, S., and Wright, A. 1987. A bacterial gene involved in transcription antitermination: Regulation at a Rho-independent terminator in the *bgl* operon of *E. coli*. *Cell* 50: 485-494.
- Manché, K., Nutley-McRobb, L., and Ferenci, T. 1999. Mutational adaptation of *Escherichia coli* to glucose limitation involves distinct pathways in anaerobic and oxygen-limited environments. *Genetics* 153: 5-12.
- Muro-Pastor, A.M., Ostrovsky, P., and Maloy, S. 1997. Regulation of gene expression by repressor localization: biochemical evidence that membrane and DNA binding by the PutA protein are mutually exclusive. *J. Bacteriol.* 179: 2788-2791.
- Nobelman, B., and Lengeler, J. 1996. Molecular analysis of the *gat* genes from *Escherichia coli* and of their roles in galactitol transport and metabolism. *J. Bacteriol.* 178: 6790-6795.
- Notley-McRobb, L., Death, A., and Ferenci, T. 1997. The relationship between external glucose concentration and cAMP levels inside *Escherichia coli*: implications for models of phosphotransferase-mediated regulation of adenylate cyclase. *Microbiology* 143: 1909-1918.
- Notley-McRobb, L., and Ferenci, T. 1999. Adaptive *mgl*-regulatory mutations and genetic diversity evolving in glucose limited *Escherichia coli* populations. *Environmental Microbiology* 1: 33-43.
- Notley-McRobb, L., and Ferenci, T. 2000. Substrate specificity and signal transduction pathways in the glucose-specific enzyme II (EII<sup>Glc</sup>) component of *Escherichia coli* phosphotransferase system. *J. Bacteriol.* 182: 4437-4442.
- Oh, H., Park, Y., and Park, C. 1999. A mutated PtsG, the glucose transporter, allows uptake of D-ribose. *J. Biol. Chem.* 274: 14006-14011.
- Ostrovsky, P., Spicer, P., and Maloy, S. 1993. PutA protein, a membrane associated flavin dehydrogenase, acts as a redox-dependent transcriptional regulator. *Proc. Natl. Acad. Sci. USA* 90: 4295-4298.
- Panagiotidis, C.H., Boos, W., and Shuman, H.A. 1998. The ATP-binding cassette subunit of the maltose transporter MalK antagonizes MalT, the activator of the *Escherichia coli mal* regulon. *Mol. Microbiol.* 30: 535-546.
- Parker, L.L., and Hall, B.G. 1990. Characterization and nucleotide sequence of the cryptic *cel* operon of *Escherichia coli* K12. *Genetics* 124: 455-471.
- Peri, K.G., Goldie, H., and Waygood, E.B. 1990. Cloning and characterisation of the N-acetylglucosamine operon of *Escherichia coli*. *Biochem. Cell Biol.* 68: 123-137.
- Peri, K.G., and Waygood, E.B. 1988. Sequence of cloned EnzymeII<sup>Nag</sup> of the phosphoenolpyruvate:N-acetylglucosamine phosphotransferase system of *Escherichia coli*. *Biochem. J.* 227: 6054-6061.
- Plumbridge, J. 1989. Sequence of the *nagBACD* operon in *Escherichia*

- coli* K12 and pattern of transcription within the *nag* regulon. *Mol. Microbiol.* 3: 506-515.
- Plumbridge, J. 1991. Repression and induction of the *nag* regulon of *Escherichia coli* K12: the roles of *nagC* and *nagA* in maintenance of the uninduced state. *Mol. Microbiol.* 5: 2053-2062.
- Plumbridge, J. 1995. Co-ordinated regulation of aminosugar biosynthesis and degradation: The NagC repressor acts as an activator for the transcription of the *glmUS* operon and requires two separated NagC binding sites. *EMBO J.* 14: 3958-3965.
- Plumbridge, J. 1998a. Control of the expression of the *manXYZ* operon in *Escherichia coli*: Mlc is a negative regulator of the mannose PTS. *Mol. Microbiol.* 27: 369-381.
- Plumbridge, J. 1998b. Expression of *ptsG*, the gene for the major glucose PTS transporter in *Escherichia coli*, is repressed by Mlc and induced by growth on glucose. *Mol. Microbiol.* 29: 1053-1063.
- Plumbridge, J. 1999. Expression of the phosphotransferase system (PTS) both mediates and is mediated by Mlc regulation in *Escherichia coli*. *Mol. Microbiol.* 33: 260-273.
- Plumbridge, J. 2000. A mutation which affects both the specificity of PtsG sugar transport and the regulation of *ptsG* expression by Mlc in *Escherichia coli*. *Microbiology* 146: 2655-2663.
- Plumbridge, J. 2001. DNA binding sites for the Mlc and NagC proteins: regulation of *nagE*, encoding the N-acetylglucosamine specific transporter in *Escherichia coli*. *Nucleic Acids Res.* 29: 506-514.
- Plumbridge, J., and Kolb, A. 1991. CAP and Nag repressor binding to the regulatory regions of the *nagE-B* and *manX* genes of *E. coli*. *J. Mol. Biol.* 217: 661-679.
- Plumbridge, J., and Kolb, A. 1993. DNA loop formation between Nag repressor molecules bound to its two operator sites is necessary for repression of the *nag* regulon of *Escherichia coli* in vivo. *Mol. Microbiol.* 10: 973-981.
- Plumbridge, J., and Kolb, A. 1995. Nag repressor-operator interactions: Protein-DNA contacts cover more than two turns of the DNA helix. *J. Mol. Biol.* 249: 809-902. (see also Corrigendum *J. Mol. Biol.* 253: 219-220).
- Plumbridge, J., and Kolb, A. 1998. DNA bending and expression of the divergent *nagE-B* operons. *Nucleic Acids Res.* 26: 1254-1260.
- Plumbridge, J.A., Cochet, O., Souza, J.M., Altamirano, M.M., Calcagno, M.L., and Badet, B. 1993. Coordinated regulation of amino sugar-synthesizing and degrading enzymes in *Escherichia coli* K-12. *J. Bacteriol.* 175: 4951-4956.
- Ramseier, T.M., Nègre, D., Cortay, J.-C., Scarabel, M., Cozzone, A.J., and Saier, M.H. 1993. *In vitro* binding of the pleiotropic transcriptional regulatory protein, FruR to the *fru*, *pps*, *ace*, *pts* and *icd* operons of *Escherichia coli* and *Salmonella typhimurium*. *J. Mol. Biol.* 234: 28-44.
- Reidl, J., and Boos, W. 1991. The *malX malY* operon of *Escherichia coli* encodes a novel Enzyme II of the phosphotransferase system recognising glucose and maltose and an enzyme abolishing the endogenous induction of the maltose system. *J. Bacteriol.* 173: 4862-4876.
- Reidl, J., Römisch, K., Ehrmann, M., and Boos, W. 1989. Mall, a novel protein involved in regulation of the maltose system of *Escherichia coli*, is highly homologous to the repressor proteins GalR, CytR, and LacI. *J. Bacteriol.* 171: 4888-4899.
- Roehl, R.A., and Vinopal, R.T. 1980. Genetic locus, distant from *ptsM*, affecting Enzyme IIA/IIB function in *Escherichia coli* K-12. *J. Bacteriol.* 142: 120-130.
- Rogers, M.J., Ohgi, T., Plumbridge, J.A., and Söll, D. 1988. Nucleotide sequences of the *Escherichia coli* *nagE* and *nagB* genes: the structural genes for the N-acetylglucosamine transport protein of the bacterial phosphoenolpyruvate:sugar phosphotransferase system and for glucosamine-6-phosphate deaminase. *Gene* 62: 197-207.
- Ryu, S., and Garges, S. 1994. Promoter switch in the *Escherichia coli* *pts* operon. *J. Biol. Chem.* 269: 4767-4772.
- Ryu, S., Ramseier, T.M., Michotey, V., Saier, M.H., and Garges, S. 1995. Effect of FruR regulator on transcription of the *pts* operon in *Escherichia coli*. *J. Biol. Chem.* 270: 2489-2496.
- Saier, M.H., Feucht, B.U., and Hofstadter, L.J. 1976. Regulation of carbohydrate uptake and adenylate cyclase activity mediated by the Enzymes II of the phosphoenolpyruvate phosphotransferase system in *Escherichia coli*. *J. Biol. Chem.* 251: 883-892.
- Saier, M.H., and Ramseier, T.M. 1996. The catabolite repressor/activator (Cra) protein of enteric bacteria. *J. Bacteriol.* 178: 3411-3417.
- Saier, M.H., Ramseier, T.M., and Reizer, J. 1996. Regulation of carbon utilization. In *Escherichia coli* and *Salmonella*. Cellular and molecular biology. (F.C. Neidhardt, C. R., J.L. Ingraham, E.C.C. Lin, K.B. Low, B. Magasanik, W.S. Reznikoff, M. Riley, M. Schaechter and H.E. Umbarger, eds), pp.1325-1343, ASM, Washington, DC.
- Scheler, A., and Hillen, W. 1994. Regulation of xylose utilization in *Bacillus licheniformis*: Xyl repressor-*xyI*-operator interactions studied by DNA modification protection and interference. *Mol. Microbiol.* 13: 505-512.
- Schnetz, K., and Rak, B. 1987. Regulation of the *bgl* operon of *Escherichia coli* by transcriptional antitermination. *EMBO J* 7: 3271-3277.
- Schultz, S.C., Shields, G.C., and Steitz, T.A. 1991. Crystal structure of a CAP-DNA complex: The DNA is bent by 90°. *Science* 253: 1001-1007.
- Schumacher, M.A., Choi, K.Y., Zalkin, H., and Brennan, R.G. 1994. Crystal structure of LacI member, PurR, bound to DNA: minor groove binding by  $\alpha$  helices. *Science* 266: 763-770.
- Sizemore, C., Buchner, E., Rygus, T., Witke, C., Götz, F., and Hillen, W. 1991. Organization, promoter analysis and transcriptional regulation of the *Staphylococcus xylosus* xylose utilization operon. *Mol. Gen. Genet.* 227: 377-384.
- Späth, C., Kraus, A., and Hillen, W. 1997. Contribution of glucose kinase to glucose repression of xylose utilization in *Bacillus megaterium*. *J. Bacteriol.* 179: 7603-7605.
- Stülke, J., Arnaud, M., Rapoport, G., and Martin-Verstraete, I. 1998. PRD - a protein domain involved in PTS-dependent induction and carbon catabolite repression of catabolic operons in bacteria. *Mol. Microbiol.* 28: 865-874.
- Takeda, S., Matsushika, A., and Mizuno, T. 1999. Repression of the gene encoding succinate dehydrogenase in response to glucose is mediated by EIICB<sup>Glc</sup> protein in *Escherichia coli*. *J. Biochem.* 128: 354-360.
- Tanaka, Y., Kimata, K., and Aiba, H. 2000. A novel regulatory role of glucose transporter of *Escherichia coli*: membrane sequestration of a global repressor Mlc. *EMBO J.* 19: 5344-5352.
- Tanaka, Y., Kimata, K., Inada, T., Tagami, H., and Aiba, H. 1999. Negative regulation of the *pts* operon by Mlc: mechanism underlying glucose induction in *Escherichia coli*. *Genes to Cells* 268: 391-399.
- Titgemeyer, F., Reizer, J., Reizer, A., and Saier, M.H. 1994. Evolutionary relationships between sugar kinases and transcriptional repressors in bacteria. *Microbiology* 140: 2349-2354.
- Valentin-Hansen, P., Sogaard-Andersen, L., and Pedersen, H. 1996. A flexible partnership: the CytR anti-activator and the cAMP-CRP activator protein, comrades in transcription control. *Mol. Microbiol.* 20: 461-466.
- Vogler, A.P., Broekhuizen, C.P., Schuitema, A., Lengeler, J.W., and Postma, P.W. 1988. Suppression of III<sup>Glc</sup>-defects by Enzymes II<sup>Nag</sup> and II<sup>Bgl</sup> of the PEP::carbohydrate phosphotransferase system. *Mol. Microbiol.* 2: 719-726.
- Vogler, A.P., and Lengeler, J.W. 1989. Analysis of the *nag* regulon from *Escherichia coli* K12 and *Klebsiella pneumoniae* and of its regulation. *Mol. Gen. Genet.* 219: 97-105.
- Vogler, A.P., and Lengeler, J.W. 1991. Comparison of the sequences of the *nagE* operons from *Klebsiella pneumoniae* and *Escherichia coli* K12: Enhanced variability of the Enzyme II<sup>N-acetylglucosamine</sup> in regions connecting functional domains. *Mol. Gen. Genet.* 230: 270-276.
- Weickert, M.J., and Adhya, S. 1992a. A family of bacterial regulators homologous to Gal and Lac repressors. *J. Biol. Chem.* 267: 15869-15874.
- Weickert, M.J., and Adhya, S. 1992b. Isorepressor of the *gal* regulon in *Escherichia coli*. *J. Mol. Biol.* 226: 69-83.
- White, R.J. 1968. Control of aminosugar metabolism in *Escherichia coli* and isolation of mutants unable to degrade amino sugars. *Biochem. J.* 106: 847-858.
- Yamada, M., and Saier, M.H. 1988. Positive and negative regulators for glucitol (*gut*) operon expression in *Escherichia coli*. *J. Mol. Biol.* 203: 569-583.
- Zeppenfeld, T., Larisch, C., Lengeler, J.W., and Jahreis, K. 2000. Glucose transporter mutants of *Escherichia coli* K-12 with changes in substrate recognition of the IICB<sup>Glc</sup> and induction behavior of the *ptsG* gene. *J. Bacteriol.* 182: 4443-4452.
- Zhou, Y., Busby, S., and Ebricht, R.H. 1993. Identification of the functional subunit of a dimeric transcription activator protein by use of oriented heterodimers. *Cell* 73: 375-379.